

JVC

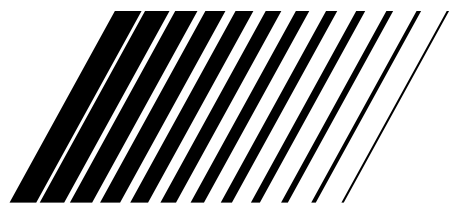

SPEAKER SYSTEM
ENCEINTE ACOUSTIQUE

SX-WD10



INSTRUCTIONS

MANUEL D'INSTRUCTIONS

For Customer Use:

Enter below the Model No. and Serial No. which are located either on the rear, bottom or side of the cabinet. Retain this information for future reference.

Model No. _____

Serial No. _____

LVT1383-002A

[J]

Thank you for purchasing JVC speaker.
Before you begin using the speaker, please read the instructions carefully.

Warnings, Cautions and Others

■ Precautions for installation

- Do not install the speakers on an uneven surface or in a place subject to vibration; otherwise, they may fall over, causing damage or injury.
 - Take the occurrence of earthquakes or other physical shocks into consideration when selecting the installation place, and secure the speakers thoroughly.
- To prevent deformation or discoloration of the cabinet, do not install the speakers where they are exposed to direct sunlight or high humidity, and avoid installation near air conditioning outlets.
- Speaker vibrations may cause howling. Place the speakers as far away from the player as possible.
- The speakers are magnetically shielded to avoid color distortions on TVs. However, if not installed properly, it may cause color distortions. So, pay attention to the following when installing the speakers.
 - When placing the speakers near a TV set, turn off the TV's main power switch or unplug it before installing the speakers. Then wait at least 30 minutes before turning on the TV's main power switch again.

Some TVs may still be affected even though you have followed the above.
If this happens, move the speakers further away from the TV.
- Tuner reception may become noisy or hissing if a speaker is installed near the tuner.
In this case, leave more distance between the tuner and the speakers or use an outdoor antenna for better tuner reception without interference from the speakers.
- Do not lean against the speakers, as the speakers could fall down or break, possibly causing an injury. Especially be careful that children do not lean against them.

■ Precautions for daily use

- **To maintain the appearance of the speakers**
 - Wipe with a dry, soft cloth if the cabinet should become dirty. If very dirty, wipe with a cloth applied a small amount of water or neutral detergent, then wipe with a dry cloth.
 - Do not use chemicals such as benzene and thinner for cleaning the cabinet.
- **To improve the sound field**
 - It is recommended to leave a space of more than 50 cm between the speakers and the wall.
 - If the speakers are facing a solid wall or glass door, etc., it is recommended to furnish the wall with materials that absorb sounds, for example by hanging up thick curtains, to prevent reflections and standing waves.
- **To use the speakers without any trouble**
 - Do not reproduce sounds at so high a volume that they are distorted; otherwise, the speakers may be damaged by internal heat buildup.
 - When moving the speakers, do not pull the speaker cords; otherwise, the speakers may fall over, causing damage or injury.

Preparation

■ Attaching the feet

To prevent the speaker from falling over, be sure to attach the supplied feet to the speaker.

- Take care not to drop the feet or speaker while assembling; otherwise, it may cause damage to the floor or injury.
- Ensure enough space for assembly and installation.
- Place a large, thick cloth on the floor where you assemble the speaker, so you can protect the floor and the speaker itself.
- Do not touch the speaker units.

1. Turn the speaker upside down.

- Turn the speaker and facing the bottom upward.

Caution:

Make sure the speaker does not fall.

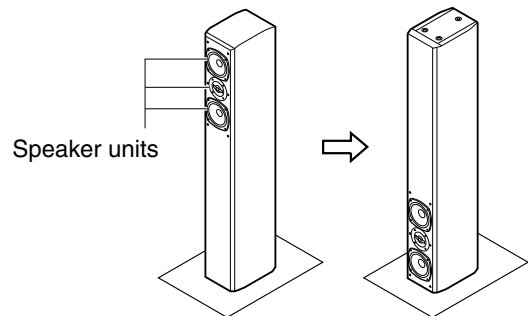

2. Attach the feet.

- Attaching the 3 feet on the bottom of the speaker.

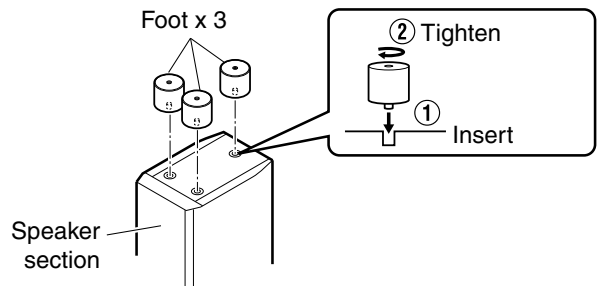

3. Attach the base.

- Prepare a Philips screwdriver.
- Attaching the base securely on the feet with the supplied three screws.

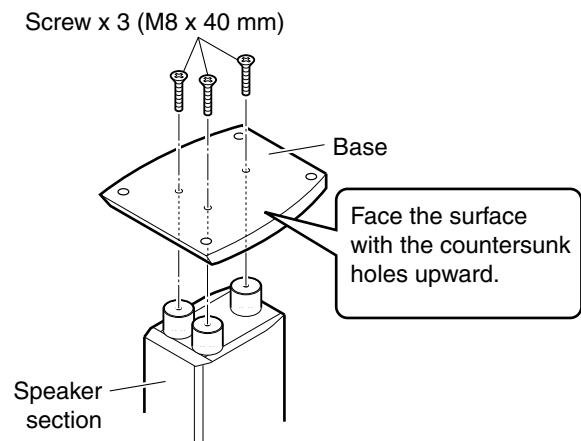

Connection

■ Precautions

Before connecting:

- Turn off the power to the amplifier before connecting the speaker system; otherwise, the speakers may be damaged.
- The impedance of the speaker is 6 Ω.
If this does not match with the speaker impedance range indicated on the amplifier, you cannot connect this system to the amplifier.
- The maximum power handling capacity of the SX-WD10 is 150 W. Excessive input will result in abnormal noise and possible damage.
- Be sure to turn down the volume level on the amplifier to prevent unwanted noise before performing following operations:
 - Turning on or off other components
 - Operating the amplifier
 - Tuning FM stations
 - Fast-forwarding a tape
 - Continuously reproducing high frequency oscillation or high pitch electronic sounds
 - Connecting or disconnecting a microphone
- When using a microphone, do not aim it at the speakers or use it near the speakers; otherwise, the howling which occurs may damage the speakers.
- Before replacing the cartridge, always turn off the power both to the amplifier and to the turntable; otherwise, the clicking noise may damage the speakers.

■ Connecting the speaker system to the amplifier

- Twist and remove the insulation at the end of each speaker cord before connecting.

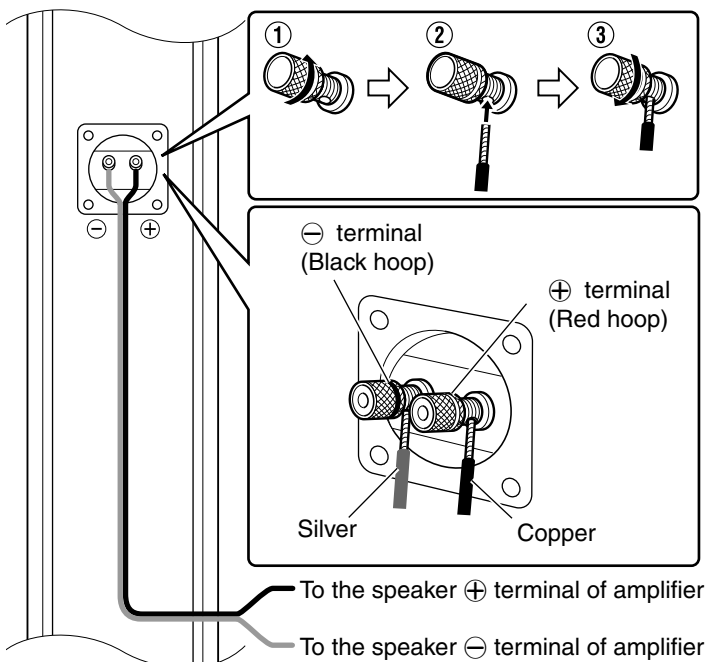
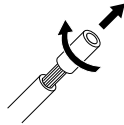

- Make sure to match the polarity (⊕ and ⊖); otherwise, the surround effect will become less effective.

About Speaker Grille

■ To remove the speaker grille

To remove the speaker grille, insert your fingers at the bottom of the speaker grille, then pull upward.

To attach the speaker grille, put the projections of the speaker into the holes of the speaker grille.

- Do not press the speaker grille strongly.



Specifications

Type	: 2-way 3-speaker bass-reflex type Magnetically-shielded type
Speaker unit	
Mid and low range	: 10.5 cm (4 ³ / ₁₆ in.) wooden cone x 2
Tweeter	: 2.0 cm (¹³ / ₁₆ in.) wooden dome x 1
Frequency range	: 150 W
Impedance	: 6 Ω
Crossover frequency	: 3.8 kHz
Frequency range	: 45 Hz to 50 000 Hz
Sound pressure level	: 85 dB/W•m
Dimensions (WxHxD)	: 270 mm x 1101 mm x 320 mm (10 ¹¹ / ₁₆ x 43 ³ / ₈ x 12 ⁵ / ₈ in.)
Mass	: 16 kg (36 lbs)
Supplied accessories	: Speaker cord (3 m) (1) Foot (3) Base (1) Screw (3)

Design and specifications subject to change without notice.



LIMITED WARRANTY

AUDIO-1

JVC COMPANY OF AMERICA (JVC) warrants this product and all parts thereof, except as set forth below ONLY TO THE ORIGINAL RETAIL PURCHASER to be FREE FROM DEFECTIVE MATERIALS AND WORKMANSHIP from the date of original purchase for the period as shown below. ("The Warranty Period")

PARTS	1 YR	LABOR	1 YR
-------	------	-------	------

THIS LIMITED WARRANTY IS VALID ONLY IN THE FIFTY (50) UNITED STATES, THE DISTRICT OF COLUMBIA AND IN THE COMMONWEALTH OF PUERTO RICO.

WHAT WE WILL DO:

If this product is found to be defective within the warranty period, JVC will repair or replace defective parts with new or rebuilt equivalents at no charge to the original owner. Such repair and replacement services shall be rendered by JVC during normal business hours at JVC authorized service centers. Parts used for replacement are warranted only for the remainder of the Warranty Period. All products may be brought to a JVC authorized service center on a carry-in basis. Color television with a screen size of 27" and or greater qualify for in-home service. In such cases, a technician will come to your home and either repair the TV there or remove and return it if it cannot be repaired in your home.

WHAT YOU MUST DO FOR WARRANTY SERVICE:

Please do not return your product to the retailer

Instead, return your product to a JVC authorized service center nearest you. If shipping the product to the service center, please be sure to package it carefully, preferably in the original packaging, and include a brief description of the problem(s). Please call 1-800-252-5722 to locate the nearest JVC authorized service center. Service locations can also be obtained from our website <http://www.jvc.com>. If your product qualifies for in-home service, the service representative will require clear access to the product.

If you have any questions concerning your Product, please contact our Customer Relations Department at 800-252-5722.

WHAT IS NOT COVERED:

This limited warranty provided by JVC does not cover:

1. Products which have been subject to abuse, accident, alteration, modification, tampering, negligence, misuse, faulty installation, lack of reasonable care, or if repaired or serviced by anyone other than a service facility authorized by JVC to render such service, or if affixed to any attachment not provided with the products, or if the model or serial number has been altered, tampered with, defaced or removed;
2. Initial installation and installation and removal from cabinets or mounting systems;
3. Operational adjustments covered in the Owner's Manual, normal maintenance, video and audio head cleaning;
4. Damage that occurs in shipment, due to act of God, and cosmetic damage;
5. Signal reception problems and failures due to line power surge;
6. Video Pick-up Tubes/CCD Image Sensors are covered for 90 days from the date of purchase;
7. Accessories;
8. Batteries (except that Rechargeable Batteries are covered for 90 days from the date of purchase);
9. Products used for commercial purposes, including, but not limited to rental.

There are no express warranties except as listed above.

THE DURATION OF ANY IMPLIED WARRANTIES, INCLUDING THE IMPLIED WARRANTY OF MERCHANTABILITY, IS LIMITED TO THE DURATION OF THE EXPRESS WARRANTY HEREIN.

JVC SHALL NOT BE LIABLE FOR THE LOSS OF USE OF THE PRODUCT, INCONVENIENCE, OR ANY OTHER DAMAGES, WHETHER DIRECT, INCIDENTAL OR CONSEQUENTIAL (INCLUDING, WITHOUT LIMITATION, DAMAGE TO TAPES, RECORDS OR DISCS) RESULTING FROM THE USE OF THIS PRODUCT, OR ARISING OUT OF ANY BREACH OF THIS WARRANTY. ALL EXPRESS AND IMPLIED WARRANTIES, INCLUDING THE WARRANTIES OF MERCHANTABILITY AND FITNESS FOR PARTICULAR PURPOSE, ARE LIMITED TO THE WARRANTY PERIOD SET FORTH ABOVE.

Some states do not allow the exclusion of incidental or consequential damages or limitations on how long an implied warranty lasts, so these limitations or exclusions may not apply to you. This warranty gives you specific legal rights and you may also have other rights which vary from state to state.

JVC COMPANY OF AMERICA 1700 Valley Road
DIVISION OF JVC AMERICAS CORP. Wayne, New Jersey 07470

<http://www.jvc.com>

REFURBISHED PRODUCTS CARRY A SEPARATE WARRANTY, THIS WARRANTY DOES NOT APPLY. FOR DETAILS OF REFURBISHED PRODUCT WARRANTY, PLEASE REFER TO THE REFURBISHED PRODUCT WARRANTY INFORMATION PACKAGED WITH EACH REFURBISHED PRODUCT.

For customer use:

Enter below the Model No. which is located either on the rear, bottom or side of the cabinet. Retain this information for future reference.

Model No. :	Serial No. :
Purchase data :	Name of dealer :

TO OUR VALUED CUSTOMER ———

THANK YOU FOR PURCHASING THIS JVC PRODUCT.
WE WANT TO HELP YOU ACHIEVE A PERFECT EXPERIENCE.

**NEED HELP ON HOW TO HOOK UP?
NEED ASSISTANCE ON HOW TO OPERATE?
NEED TO LOCATE A JVC SERVICE CENTER?
LIKE TO PURCHASE ACCESSORIES?**

JVC[®] IS HERE TO HELP!
TOLL FREE: 1(800)252-5722
<http://www.jvc.com>

Remember to retain your Bill of Sale for Warranty Service.

————— **Do not attempt to service the product yourself** —————

Caution

To prevent electrical shock, do not open the cabinet.
There are no user serviceable parts inside.
Please refer to qualified service personnel for repairs.

JVC